

■ General Description

The AME8833 family of positive, linear regulators feature low quiescent current (50 μ A typ.) low dropout voltage and excellent PSRR, thus making them ideal for Telecommunications and other battery applications. The ultra-small SC-70 package is attractive for "Pocket" and "Hand Held" applications.

AME8834's output voltage can be adjusted with an external resistor divider.

These rugged devices have both Thermal Shutdown, and Current Fold-back to prevent device failure under the "Worst" of operating conditions.

As an additional feature, the AME8833/8834 is stable with an output capacitance of just extended 0.22 μ F or greater.

■ Features

- Stable with only 0.22 μ F output Cap
- Very Low Dropout Voltage
- Guaranteed 150mA Output
- Accurate to within 1.0%
- 50 μ A Quiescent Current
- Over-Temperature Shutdown
- Current Limiting
- Short Circuit Current Fold-back
- Excellent PSRR (Typ. 70dB)
- Power-Saving Shutdown Mode
- Ultra-small SC-70 and SOT-25-L Package
- Factory Pre-set Output Voltages
- Low Temperature Coefficient
- Input Voltage Range (2V - 5.5V)

■ Applications

- Cellular Phones
- Instrumentation
- Portable Electronics
- Wireless Devices
- Cordless Phones
- PC Peripherals
- Battery Powered Widgets
- Electronic Scales
- Cameras
- Telecommunications

■ Functional Block Diagram

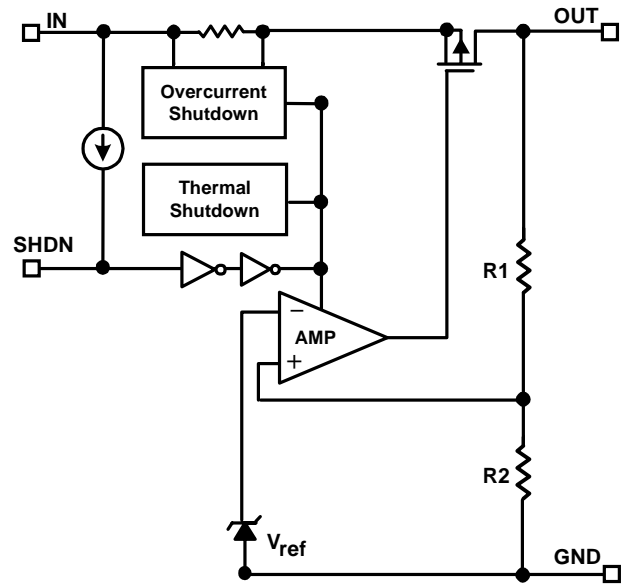

■ Typical Application

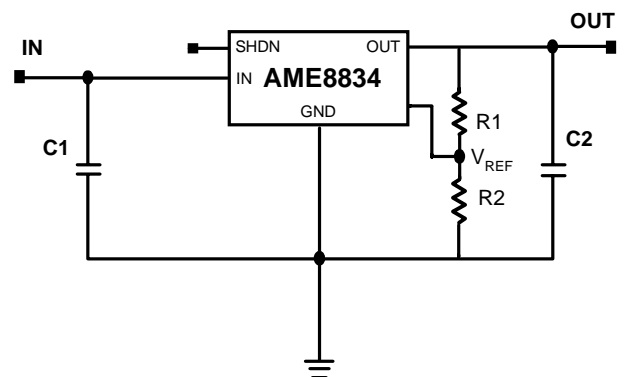
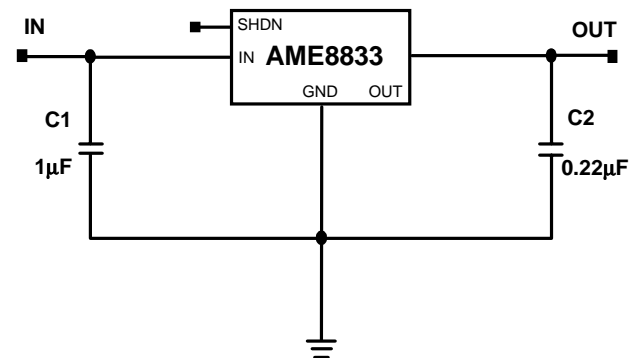

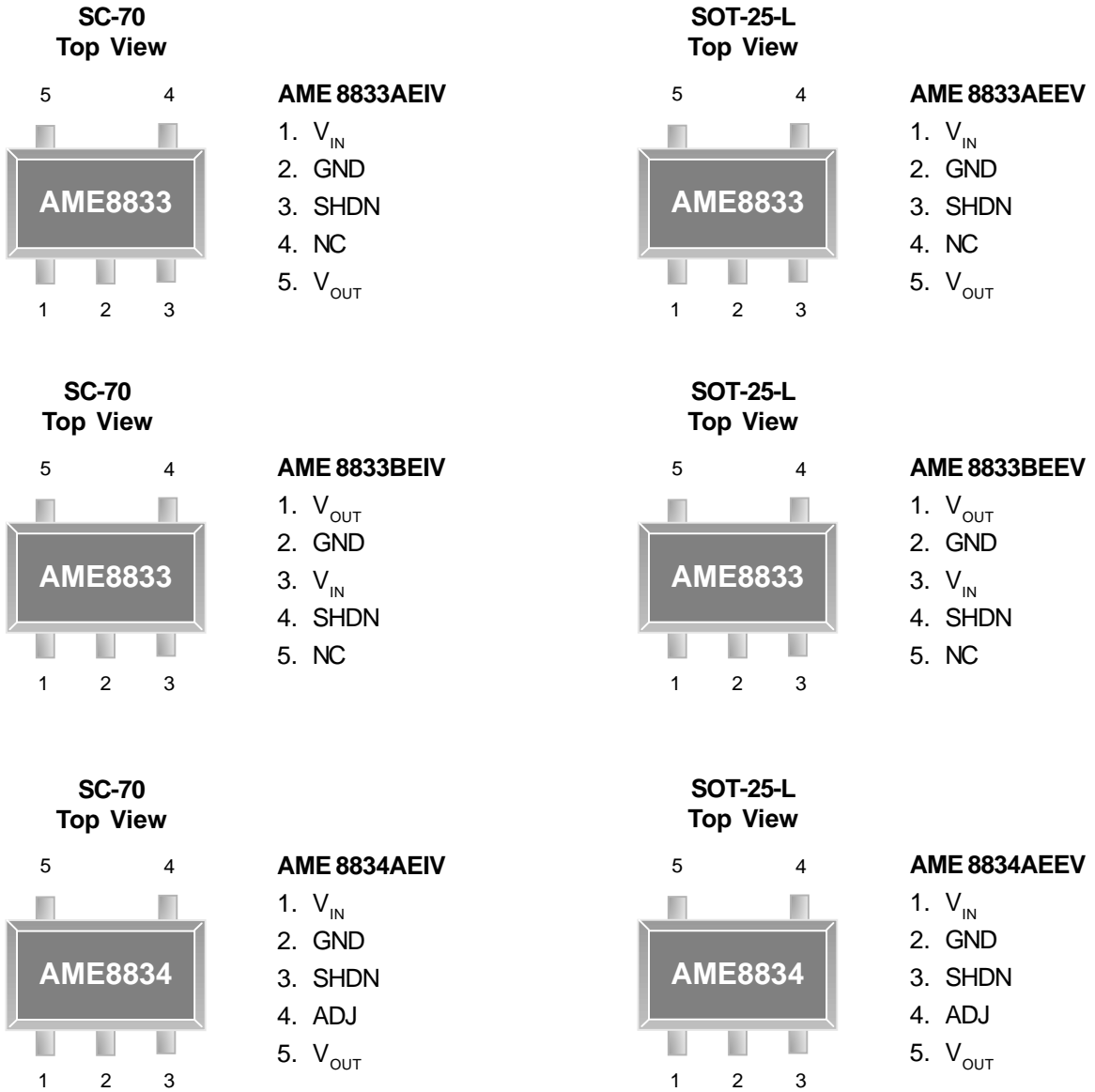
■ Pin Configuration



■ Ordering Information

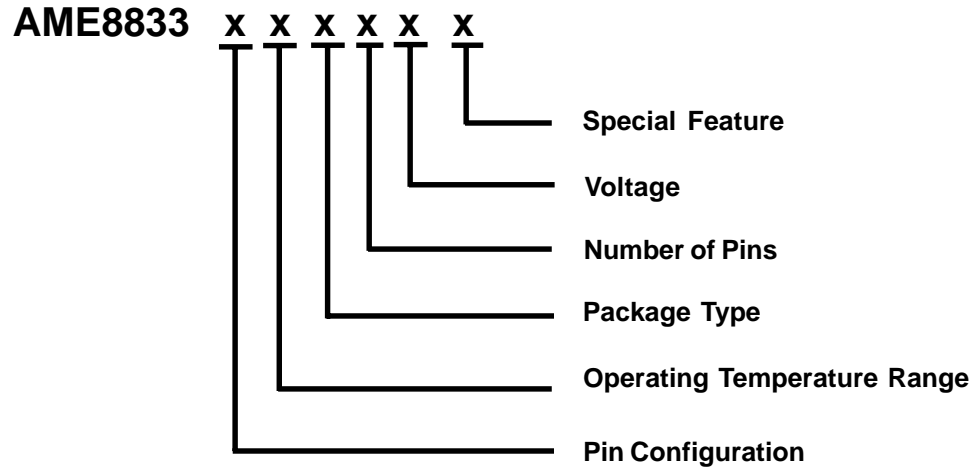

Pin Configuration	Operating Temperature Range	Package Type	Number of Pins	Voltage	Special Feature
A: 1. VIN 2. GND 3. SHDN 4. NC 5. VOUT B: 1. VOUT 2. GND 3. VIN 4. SHDN 5. NC	E: -40°C to 85°C	E: SOT-2X I: SC-70	V: 5	180: V=1.8V 200: V=2.0V 250: V=2.5V 270: V=2.7V 280: V=2.8V 285: V=2.85V 300: V=3.0V 320: V=3.2V 330: V=3.3V	L: Low profile Y: Lead free & Low profile Z: Lead free



■ Ordering Information

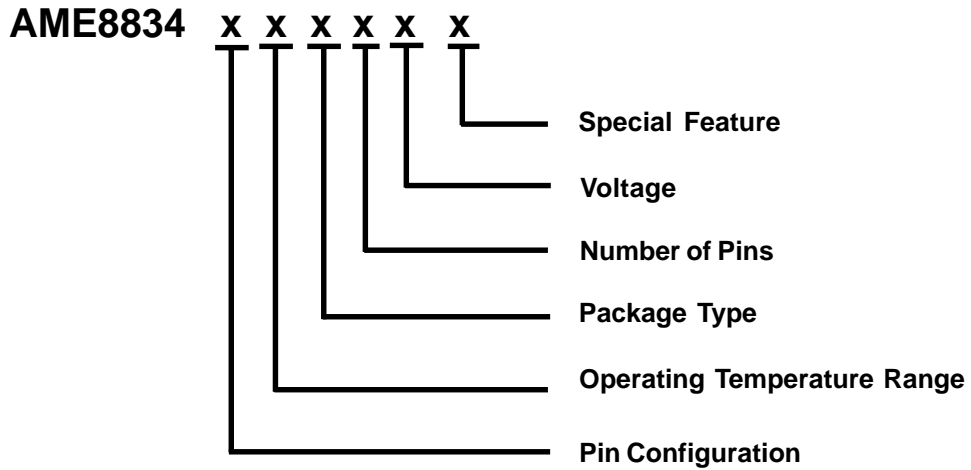

Pin Configuration	Operating Temperature Range	Package Type	Number of Pins	Voltage	Special Feature
A: 1. VIN 2. GND 3. SHDN 4. ADJ 5. VOUT	E: -40°C to 85°C	E: SOT-2X I: SC-70	V: 5	ADJ: Adjustable	L: Low profile Y: Lead free & Low profile Z: Lead free

■ Ordering Information

Part Number	Marking	Output Voltage	Package	Operating Temp. Range
AME8833AEIV180	AWAw	1.8V	SC-70	- 40°C to + 85°C
AME8833AEIV250	AWBw	2.5V	SC-70	- 40°C to + 85°C
AME8833AEIV270	AXFw	2.7V	SC-70	- 40°C to + 85°C
AME8833AEIV280	AWDw	2.8V	SC-70	- 40°C to + 85°C
AME8833AEIV285	AVZw	2.85V	SC-70	- 40°C to + 85°C
AME8833AEIV300	AWEw	3.0V	SC-70	- 40°C to + 85°C
AME8833AEIV320	AXGw	3.2V	SC-70	- 40°C to + 85°C
AME8833AEIV330	AWCw	3.3V	SC-70	- 40°C to + 85°C
AME8833AEEV180L	AWMww	1.8V	SOT-25	- 40°C to + 85°C
AME8833AEEV250L	AWNww	2.5V	SOT-25	- 40°C to + 85°C
AME8833AEEV270L	AXEww	2.7V	SOT-25	- 40°C to + 85°C
AME8833AEEV280L	AWOww	2.8V	SOT-25	- 40°C to + 85°C
AME8833AEEV285L	AWPww	2.85V	SOT-25	- 40°C to + 85°C
AME8833AEEV300L	AWQww	3.0V	SOT-25	- 40°C to + 85°C
AME8833AEEV330L	AWRww	3.3V	SOT-25	- 40°C to + 85°C
AME8833AEIV180Z	AWAw	1.8V	SC-70	- 40°C to + 85°C
AME8833AEIV250Z	AWBw	2.5V	SC-70	- 40°C to + 85°C
AME8833AEIV280Z	AWDw	2.8V	SC-70	- 40°C to + 85°C
AME8833AEIV285Z	AVZw	2.85V	SC-70	- 40°C to + 85°C
AME8833AEIV300Z	AWEw	3.0V	SC-70	- 40°C to + 85°C
AME8833AEIV330Z	AWCw	3.3V	SC-70	- 40°C to + 85°C
AME8834AEIVADJ	AWJw	Adjustable	SC-70	- 40°C to + 85°C

Note: w represents date code (A thru Z) : 2 work weeks per character.

Please consult AME sales office or authorized Rep./Distributor for other output voltage and package type availability.



■ Absolute Maximum Ratings

Parameter	Maximum	Unit
Input Voltage	6	V
Output Current	$P_D / (V_{IN} - V_O)$	mA
Output Voltage	GND - 0.3 to $V_{IN} + 0.3$	V
ESD Classification	B	

Caution: Stress above the listed absolute maximum rating may cause permanent damage to the device

■ Recommended Operating Conditions

Parameter	Rating	Unit
Ambient Temperature Range	- 40 to + 85	°C
Junction Temperature	- 40 to + 125	°C

■ Thermal Information

Parameter		Maximum	Unit
Thermal Resistance (θ_{ja})	SOT-25	260	°C / W
Thermal Resistance (θ_{jc})	SOT-25	81	°C / W
Thermal Resistance (θ_{ja})	SC-70	331	°C / W
Thermal Resistance (θ_{jc})	SC-70	224	°C / W
Maximum Junction Temperature		150	°C
Maximum Lead Temperature (10 Sec)		300	°C

■ Electrical Specifications

$V_{IN}=V_{OUT}+0.5V$, $V_{SHDN}=V_{IN}$, $TA = 25^{\circ}C$, $C_{IN}=C_{OUT}=1\mu F$, AME8834 is tested with 2.45V output, unless otherwise noted

Parameter	Symbol	Test Condition		Min	Typ	Max	Units	
Input Voltage	V_{IN}			Note1		5.5	V	
Output Voltage Accuracy	V_O	$I_O=0.1mA$	AME8833	25°C	-1	1	%	
				-40°C~85°C	-2	2		
			AME8834	25°C	-1.5	1.5		
				-40°C~85°C	-2.5	2.5		
		$I_O=150mA$	AME8833	25°C	-2	2	%	
				-40°C~85°C	-2.5	2.5		
AME8834	25°C	-2	2					
	-40°C~85°C	-2.5	2.5					
Dropout Voltage	$V_{DROPOUT}$	$I_O=150mA$ $V_{OUT}=V_{O(NOM)} -2\%$	$V_{OUT} \geq 2.0V$			500	mV	
			$V_{OUT} < 2.0V$			1000		
Current Limit	I_{LIM}	$V_O > 800mV$		150	200		mA	
Foldback Current	I_{FB}	$V_O = 0V$			80		mA	
Quiescent Current	I_Q	$V_{IN}=5V$, $I_O=0mA$			60		μA	
Ground Pin Current	I_{GND}	$V_{IN}=5V$, $I_O = 1mA$ to 150mA			50		μA	
Line Regulation	REG_{LINE}	$I_O=0.1mA$, $V_{OUT}>2.0V$ $V_{IN}=V_{OUT}+0.5V$ to 5.5V		-0.2		0.2	%	
		$I_O=0.1mA$, $V_{OUT}\leq 2.0V$ $V_{IN}=V_{OUT}+1V$ to 5.5V		-0.4		0.4		
Load Regulation	REG_{LOAD}	$I_O=0.1$ to 150mA	$V_{OUT}>2.0V$ $V_{IN}=V_{OUT}+0.5V$	-1		1	%	
			$V_{OUT}\leq 2.0V$ $V_{IN}=V_{OUT}+1V$	-2		2		
Over Temperature Shutdown	OTS				137		°C	
Over Temperature Hysteresis	OTH				23		°C	
V_O Temperature Coefficient	TC				30		ppm/°C	
Power Supply Rejection	PSRR	$R_O=100\Omega$ $C_O=0.22\mu F$	$f=1kHz$		70		dB	
Output Voltage Noise	eN	$f=10Hz$ to 100kHz $I_O=10mA$	$C_O=0.22\mu F$		30		μV_{rms}	
SHDN Input Threshold	V_{SHDNH}	$V_{SHDN} = 0.8 \times V_{IN}$		$0.8 \times V_{IN}$		V_{in}	V	
	V_{SHDNL}	$V_{SHDN} = 0.6V$		0		0.6	V	
SHDN Input Bias Current		$V_{IN} = 5V$ $EN = 0V$ or 5V	$TA = 25^{\circ}C$			0.01	μA	
			$TA = 85^{\circ}C$			0.1		
Shutdown Supply Current	I_{SD}	$V_{IN}=5V$ $V_O=0V$	$TA=25^{\circ}C$			0.5	1	μA
			$TA=85^{\circ}C$			1		
Shutdown Output Voltage	$V_{O,SD}$	Output Loading ≤ 1200 ohm, $V=0V$		0		0.4	V	
ADJ Referenece Voltage (AME8834)	V_{REF}			1.206	1.225	1.243	V	
ADJ Input Bias Current (AME8834)		$V_{IN}=5.5V$ $V_{ADJ}=1.3V$	$TA = 25^{\circ}C$			0.05	0.1	μA
			$TA = 85^{\circ}C$			0.1		

Note1: $V_{IN(min)} = V_{OUT} + V_{DROPOUT}$



■ Detailed Description

The AME8833/8834 family of CMOS regulators contain a PMOS pass transistor, voltage reference, error amplifier, over-current protection, and thermal shutdown.

The P-channel pass transistor receives data from the error amplifier, over-current shutdown, and thermal protection circuits. During normal operation, the error amplifier compares the output voltage to a precision reference. Over-current and Thermal shutdown circuits become active when the junction temperature exceeds 150°C, or the current exceeds 150mA. During thermal shutdown, the output voltage remains low. Normal operation is restored when the junction temperature drops below 120°C.

The AME8833/8834 switches from voltage mode to current mode when the load exceeds the rated output current. This prevents over-stress. The AME8833/8834 also incorporates current foldback to reduce power dissipation when the output is short circuited. This feature becomes active when the output drops below 0.8volts, and reduces the current flow by 65%. Full current is restored when the voltage exceeds 0.8 volts.

■ External Capacitors

The AME8833/8834 is stable with an output capacitor to ground of 0.22µF or greater. Ceramic capacitors have the lowest ESR, and will offer the best AC performance. Conversely, Aluminum Electrolytic capacitors exhibit the highest ESR, resulting in the poorest AC response.

A second capacitor is recommended between the input and ground to stabilize V_{in} . The input capacitor should be at least 1µF to have a beneficial effect.

A larger capacitor improves the AC ripple rejection, but also makes the output come up slowly. This "Soft" turn-on is desirable in some applications to limit turn-on surges.

All capacitors should be placed in close proximity to the pins. A "Quiet" ground termination is desirable. This can be achieved with a "Star" connection.

■ Shutdown

When actively, pulled low, the PMOS pass transistor shuts off, and all internal circuits are powered down. In this state, the quiescent current is less than 1µA. This pin behaves much like an electronic switch.

■ Adjustable Version

AME8834 features a user-adjustable output through an external feedback resistor divider. To set the output of AME8834 use the following equation:

$$V_{OUT} = V_{ADJ} (1 + R1/R2)$$

$V_{ADJ} = 1.225V$, use 1% or better resistors



Input Current vs. Input Voltage

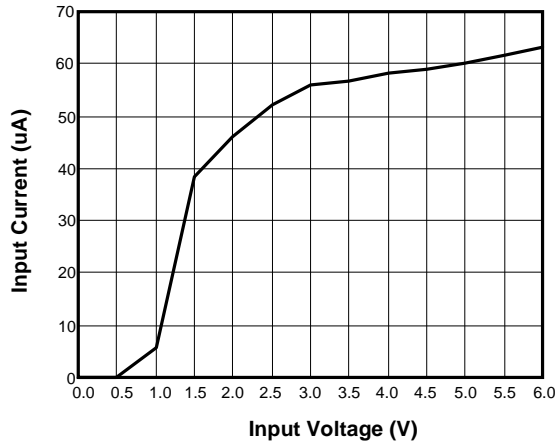

Input Current vs. Temperature

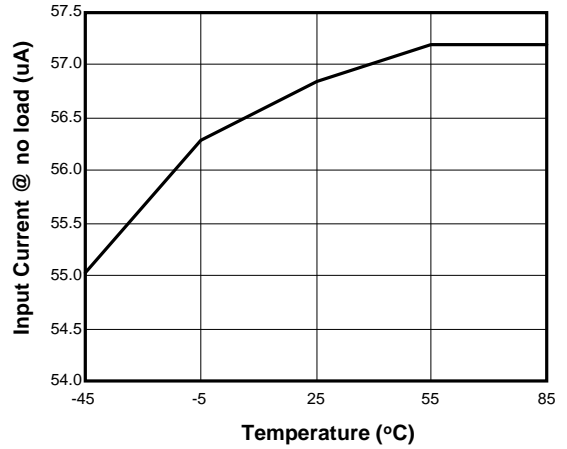

Dropout Voltage vs. Load

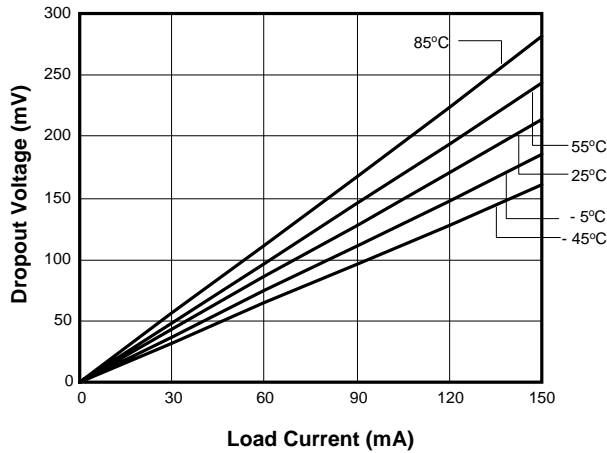

Output Voltage vs. Temperature

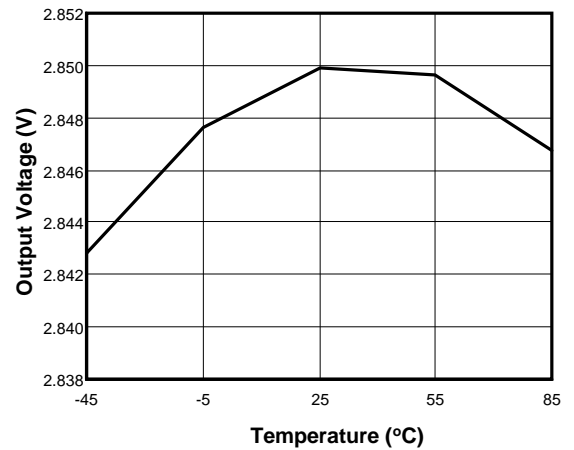

Output Voltage vs. Load Current

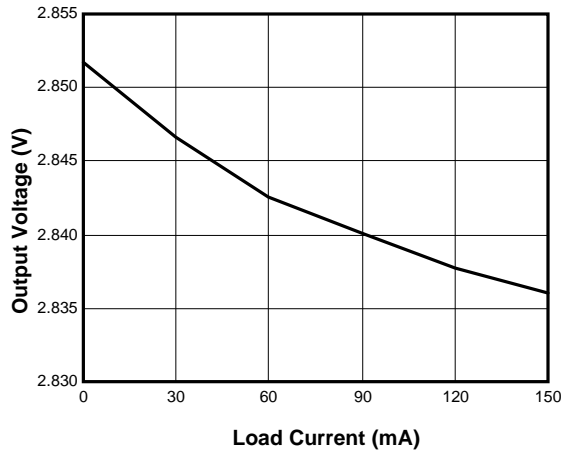

Output Voltage vs. Input Voltage

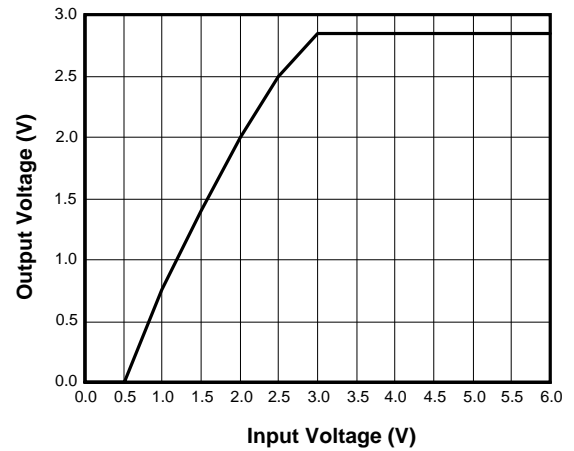

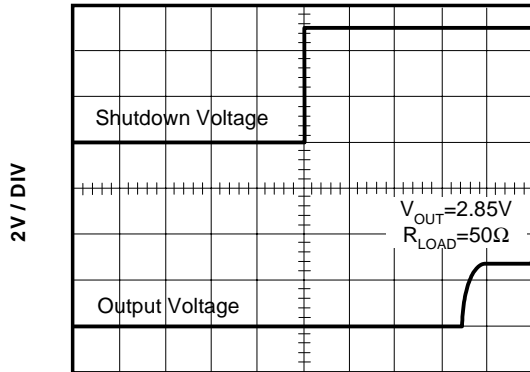
Exiting Shutdown Waveform

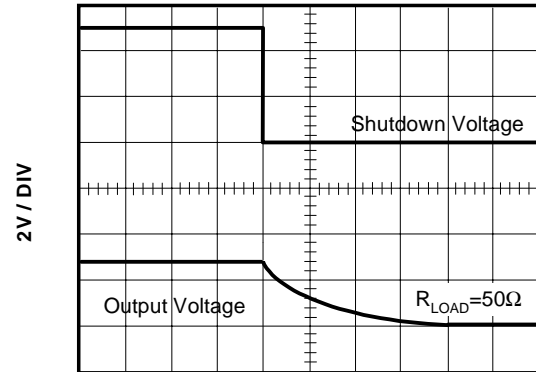
 10 μ S / DIV

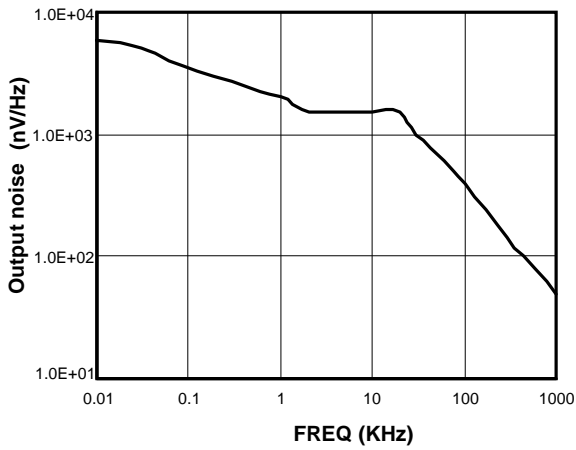
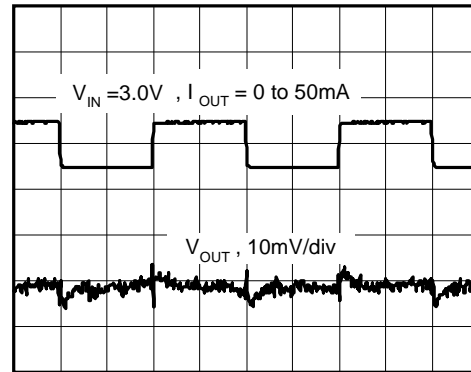
Entering Shutdown Waveform

 10 μ S / DIV

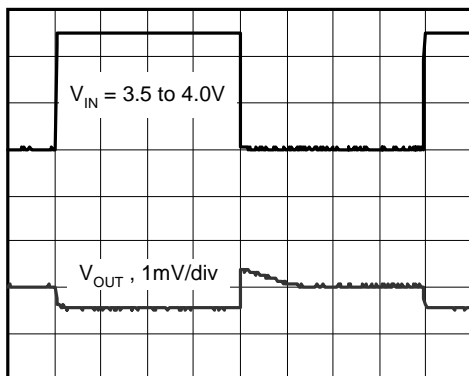
Output Noise Spectral Density vs. Frequency

Line Transient Response

200uS/div

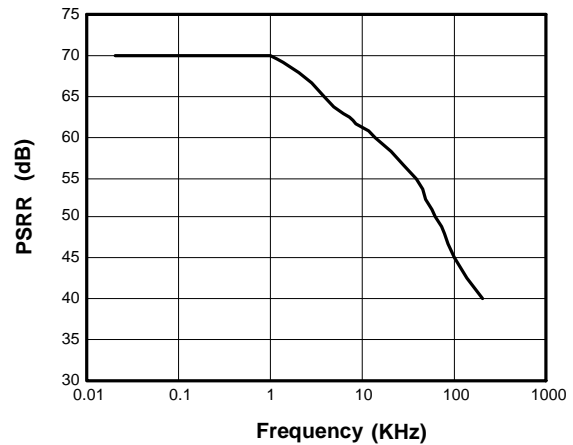
Load Transient Response

1mS/div

PSRR vs. Frequency



Dropout Voltage vs. Output Voltage

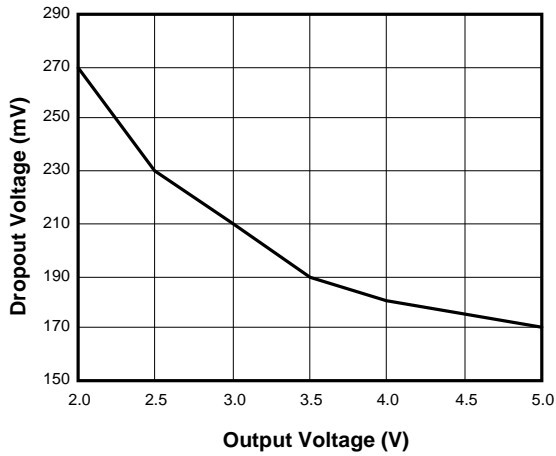

Region of Stable Cout ESR vs. Load Current

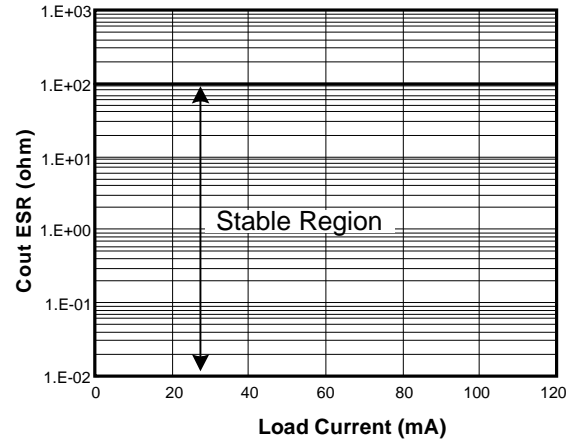

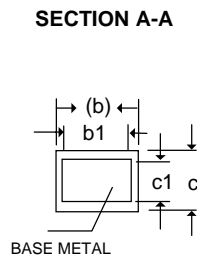
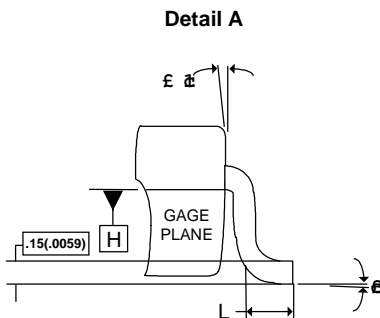
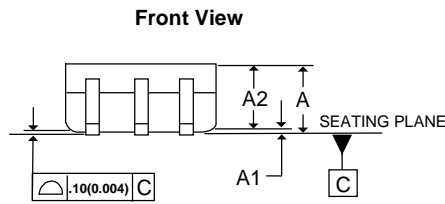
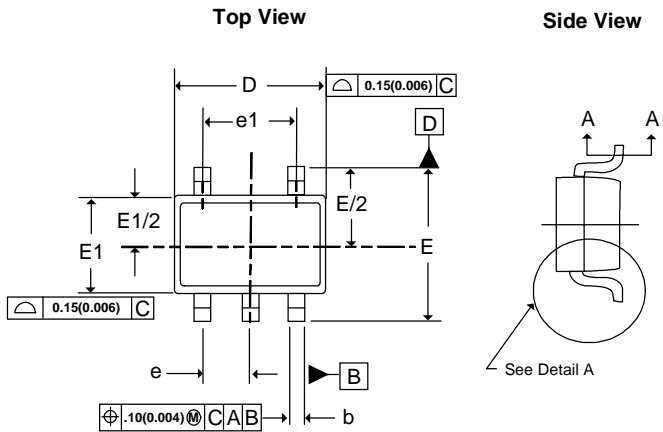
■ Package Dimension
SC-70

SYMBOLS	MILLIMETERS		INCHES	
	MIN	MAX	MIN	MAX
A	0.80	1.10	0.031	0.043
A1	0.00	0.10	0.000	0.004
A2	0.80	1.00	0.031	0.040
b	0.15	0.30	0.006	0.012
b1	0.15	0.25	0.006	0.010
c	0.08	0.25	0.003	0.010
c1	0.08	0.20	0.003	0.008
D	1.90	2.15	0.074	0.084
E	2.00	2.20	0.078	0.086
E1	1.15	1.35	0.045	0.055
e	0.65BSC		0.0255BSC	
e1	1.30BSC		0.0512BSC	
L	0.26	0.46	0.010	0.018
θ1	0°	8°	0°	8°
θ2	4°	10°	4°	10°

NOTE:

1. Controlling Dimension : Millimeter, converted inch dimension are not necessarily exact.
2. Dimensioning and tolerancing per ansi Y14.5m-1994.
3. Dimension "d" does not include mold flash, protrusion or gate burr, mold flash, protrusion or gate burr shall not exceed 0.15mm(0.006") per end. Dimension E1 do not include inter-lead flash or protrusion, inter-lead flash or protrusion shall not exceed 0.15mm(0.006") per side.
4. The package top be smaller than the package bottom. Dimension D and E1 are determined at outermost extremes of the plastic body exclusive of mold flash, tie bar burrs, gate burrs and interlead flash, but including any mismatch between the top and bottom of the plastic body.



■ Package Dimension

SOT-25-L

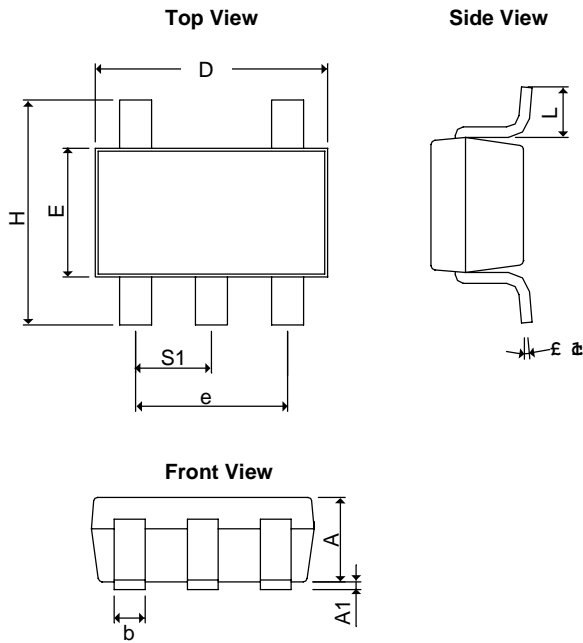

SYMBOLS	MILLIMETERS		INCHES	
	MIN	MAX	MIN	MAX
$A+A_1$	1.00	1.30	0.0394	0.0512
b	0.30	0.55	0.0118	0.0217
D	2.70	3.10	0.1063	0.1220
E	1.40	1.80	0.0551	0.0709
e	1.90 BSC		0.07480 BSC	
H	2.60	3.00	0.10236	0.11811
L	0.37BSC		0.0146BSC	
θ_1	0°	10°	0°	10°
S_1	0.95BSC		0.0374BSC	



www.ame.com.tw
E-Mail: sales@ame.com.tw

Life Support Policy:

These products of AME, Inc. are not authorized for use as critical components in life-support devices or systems, without the express written approval of the president of AME, Inc.

AME, Inc. reserves the right to make changes in the circuitry and specifications of its devices and advises its customers to obtain the latest version of relevant information.

© AME, Inc. , February 2004

Document: 2029-DS8833/8834-C

Corporate Headquarter
AME, Inc.

2F, 189 Kang-Chien Road, Nei-Hu Distric
Taipei 114, Taiwan, R.O.C.
Tel: 886 2 2627-8687
Fax: 886 2 2659-2989

U.S.A. (Subsidiary)
Analog Microelectronics, Inc.

3100 De La Cruz Blvd., Suite 201
Santa Clara, CA. 95054-2046
Tel : (408) 988-2388
Fax: (408) 988-2489